

INSTALLATION MANUAL GPS/PLOTTER/SOUNDER GP-1810F

1. EQUIPMENT LISTS	1
2. DISPLAY UNIT	7
3. ANTENNA UNIT	8
4. TRANSDUCER	11
5. SPEED/TEMPERATURE SENSOR	17
6. WIRING	19
7. INITIAL SETTINGS	22
OUTLINE DRAWINGS	D-1
INTERCONNECTION DIAGRAM	S-1
SCHEMATIC DIAGRAMS	S-2



© FURUNO ELECTRIC CO., LTD.

9-52, Ashihara-cho,
Nishinomiya, Japan 662

Telephone: 0798-65-2111
Telefax: 0798-65-4200

All rights reserved. Printed in Japan

·Your Local Agent/Dealer

FIRST EDITION : MAY 1996
B : OCT. 21, 1997

(TATA)

PUB. No. IME-43781-B
GP-1810F





SAFETY INSTRUCTIONS

"**DANGER**", "**WARNING**" and "**CAUTION**" notices appear throughout this manual. It is the responsibility of the installer of the equipment to read, understand and follow these notices. If you have any questions regarding these safety instructions, please contact a FURUNO agent or dealer.



DANGER

This notice indicates a potentially hazardous situation which, if not avoided, will result in death or serious injury.



WARNING

This notice indicates a potentially hazardous situation which, if not avoided, could result in death or serious injury.



CAUTION

This notice indicates a potentially hazardous situation which, if not avoided, could result in minor or moderate injury, or property damage.

WARNING



This equipment uses high voltage electricity which can shock, burn, or cause death.

Only qualified personnel should work inside the equipment.

Serious injury or death can result if the power is applied while the equipment is being installed.

Turn off the power at the ship's mains switchboard before beginning the installation. Post a warning sign near the switch board indicating that the switch should not be turned on while the equipment is being installed.

CAUTION



Ground the equipment to prevent electrical shock or mutual interference.

Confirm that the power supply voltage is compatible with the voltage rating of the equipment.

Connection to the wrong power supply can cause fire or equipment damage. The voltage rating appears on the label at the rear of the equipment.

1. EQUIPMENT LISTS

	Name	Type	Qty	Wt. (kg)	Remarks
1	Antenna Unit	GPA-016	1	0.1	
2	Display Unit	GP-1801F	1	3.0	
3	Installation Materials	CP14-04720	1		See page 3.
		CP14-04730			
4	Spare Parts	SP20-00600	1 set		

Options

	Name	Type	Code No.	Remarks
1	Antenna Cable Set	CP20-01700	004-372-110	30m, For extending antenna cable
2	Antenna Cable Set	CP20-01710	004-372-120	50m, For extending antenna cable
3	Right Angle Antenna Base	No.13-QA330	000-803-239	For antenna unit
4	L-Type Antenna Base	No.13-QA310	000-803-240	
5	Handrail Antenna Base	No.13-RC5160	000-806-114	
6	Mast Mount Kit	CP20-01111	000-040-722	
7	Speed/Temperature Sensor	ST-01MSB	000-109-505	Bronze, thru-hull mount
8	Temperature Sensor	T-02MTB	000-040-026	W/8m cable, Transom mount
		T-03MSB	000-040-027	W/8m cable, Thru-hull mount
		T-02MSB	000-040-040	W/8m cable, Thru-hull mount
9	Flush Mount Kit S	OP14-35	004-369-810	
10	Flush Mount Kit F	OP14-36	004-369-820	
11	RAM Card	00RAM256C-001	004-321-070	
		00RAM512C-002	004-322-230	

	Name	Type	Code No.	Remarks
12	Transducer	520-5PSC-A	000-015-229	W/8m cable, Thru-hull mount Plastic, Cable assembly 02S4089 (Code no. 000-133-622) required
		520-5MSC-A	000-015-230	W/8m cable, Thru-hull mount Bronze, Cable assembly 02S4089 (Code no. 000-133-622) required
		520-5PWC	000-015-108	W/8m cable Transom mount, Cable assembly 02S4089 (Code no. 000-133-622) required
		520-5PSD	000-015-125	W/8m cable, Waterproof connector fitted. Transducers same as above.
		520-5MSD	000-015-127	
		520-5PWD	000-015-126	
		50/200-1T	000-015-170	W/10m cable, Distribution box MB-1000 (Code no. 000-040-809) required.
		50B-6 *10m*	000-015-042	Distribution box MB-1000 (Code No.000-040-809) or Cable assembly 02S4069-0 (Code No.000-127-679) required.
		50B-6G *10m*	000-015-016	
		200B-5 *10m*	000-015-027	
		200B-5S *10m*	000-015-029	
		13	Triducer	520ST-PWD
14	Cable Assy for TXR cable	02S4069	000-127-679	
		02S4089	000-133-622	8P-10P conv.
15	Signal Cable	MJ-A6SPF0011-050	000-132-244	6P-4P, 5m
		MJ-A6SPF0011-100	000-132-336	6P-4P, 10m
		MJ-A6SPF0012-050 64S4073	000-134-424	Cross Cable 5m
		MJ-A6SPF0012-100 64S4071	000-133-817	Cross Cable 10m
		20S0241-0	000-136-730	for DGPS
		20S0093	000-117-603	5m, One end Connector
16	Inner Hull Kit S	22S0191-0	000-802-598	For transducer
17	Distribution Box	MB-1000	000-040-809	

PACKING LIST

GP-1810F-E/J-0

14BX-X-9853-1

工事材料

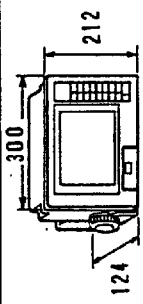
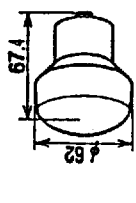

INSTALLATION MATERIALS CP14-04730

NAME	OUTLINE	DESCRIPTION/CODE No.	Q'TY
指示器 DISPLAY UNIT		GP-1810F-E/J	1
空中線部 ANTENNA UNIT		GPA-016 000-040-537	1

予備品

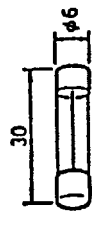
SPARE PARTS SP20-00600

管入りヒューズ FUSE		FGBO-A 5A AC125V 000-549-064	3
-----------------	---	---------------------------------	---

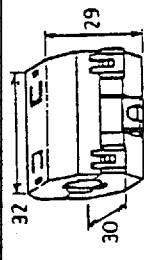
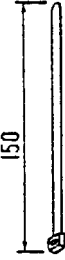
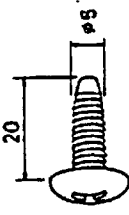
電源ケーブル POWER CABLE		03S9148 000-129-613	1
アンテナケーブル組品 ANTENNA CABLE ASSY.		TNC-PS-3D-15 (20S0216) 000-133-670	1
EMI コア EMI CORE		ESD-SR-25 000-123-303	1
コンベックス PLASTIC BAND		CV-150 000-570-325	1
+トラスタップングネジ TAPPING SCREW		5x20 SUS 304 000-802-081	5

PACKING LIST

GP-1810F-E/J-1

14BX-X-9854-1

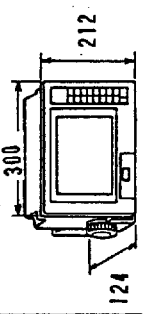
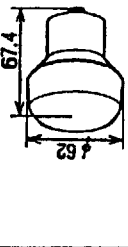
NAME	OUTLINE	DESCRIPTION/CODE No.	Q'TY
指示部 DISPLAY UNIT		GP-1810F-E/J	1
空中線部 ANTENNA UNIT		GPA-016 000-040-537	1





予備品

SPARE PARTS SP20-00600

管入りヒューズ FUSE		FGBO-A 5A AC125V 000-549-064	3
-----------------	---	---------------------------------	---

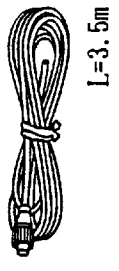
工事材料

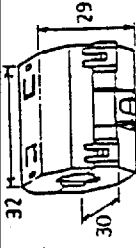
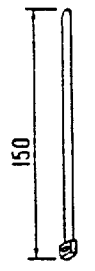
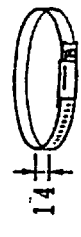
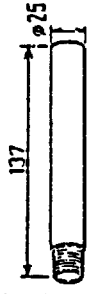
INSTALLATION MATERIALS CP14-04720

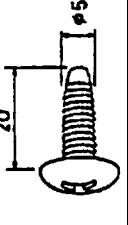
電源ケーブル POWER CABLE		03S9148 000-129-613	1
アンテナケーブル組品 ANTENNA CABLE ASSY.		TNC-PS-3D-15 (20S0216) 000-133-670	1
EMIコア		ESD-SR-25 000-123-303	1
コンベックス PLASTIC BAND		CV-150 000-570-325	1
パーカークランプ HOSE CLAMP		6348 SUS 304 000-805-906	2
パイプ PIPE		20-007-3011-2 100-183-262	1
取付補助金具 INSTALLING SPACER		20-007-3012-1 100-183-271	1
+トラスタップネジ TAPPING SCREW		5x20 SUS 304 000-802-081	5

FURUNO

CODE NO.	004-372-110
TYPE.	CP20-01700

工事材料表 INSTALLATION MATERIALS	アンテナケーブルセット ANTENNA CABLE SET	Option
---------------------------------	----------------------------------	--------

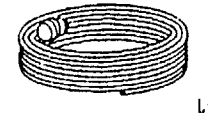
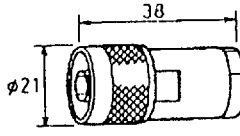
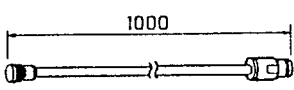
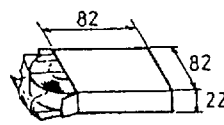
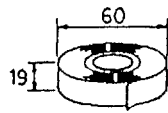
番号 No.	名称 NAME	略図 OUTLINE	型名 / 規格 DESCRIPTIONS	数量 Q'TY	用途 / 備考 REMARKS
1	アンテナケーブル組品 ANTENNA CABLE ASSY.		8D-FB-CV *30M* CODE NO. 000-111-547	1	
2	同軸コネクタ COAX. CONNECTOR		N-P-8DFB CODE NO. 000-111-549	1	
3	変換ケーブル組品 COAX. COUPLING CABLE ASSY.		NJ-TP-3DXV-1 (3D-XV *1M*) CODE NO. 000-123-809	2	
4	絶縁テープ SELF-BONDING TAPE		U-TAPE 0.5X19X5M CODE NO. 000-800-985	1	
5	ビニールテープ NO.360 VINYL TAPE		0.2X19X10000 20/BLK IADJ/ETHLON CODE NO. 000-835-215	1	
			CODE NO.		
			CODE NO.		
			CODE NO.		
			CODE NO.		
			CODE NO.		

GP-50MARK-2, GP-50MARK-3, GP-70MARK-2
 GP-1800/1800F, GP-1810/1810F, GP-1800MARK-2
 GP-8000, GP-8000MARK-2, GP-8000MARK-2SH

図番 (1/1)
DWG. NO. C0014-M19-C

CODE NO	004-372-120
TYPE	CP20-01710

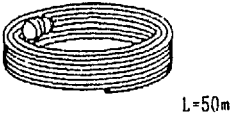
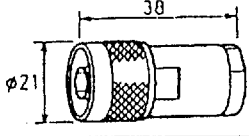
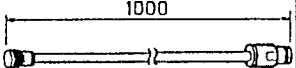
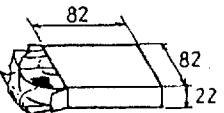
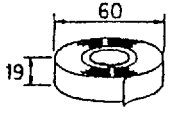
工事材料表 INSTALLATION MATERIALS		アンテナケーブルセット ANTENNA CABLE SET			Option
番号 No.	名称 NAME	略図 OUTLINE	型名 / 規格 DESCRIPTIONS	数量 Q'TY	用途 / 備考 REMARKS
1	アンテナケーブル組品 ANTENNA CABLE ASSY.		8D-FB-CV *50M*	1	
			CODE NO		
2	同軸コネクタ COAX. CONNECTOR		N-P-8DFB	1	
			CODE NO		
3	変換ケーブル組品 COAX. COUPLING CABLE ASSY.		NJ-TP-3DXV-1 (3D-XV *1M*)	2	
			CODE NO		
4	絶縁テープ SELF-BONDING TAPE		U-TAPE 0.5X19X5M	1	
			CODE NO		
5	ビニールテープ NO.360 VINYL TAPE		0.2X19X10000 20/BLK IACON/ETHLON	1	
			CODE NO		
			CODE NO		
			CODE NO		
			CODE NO		
			CODE NO		
			CODE NO		

GP-50MARK-2, GP-50MARK-3, GP-70MARK-2
 GP-1800/1800F, GP-1810/1810F, GP-1800MARK-2
 GP-8000, GP-8000MARK-2, GP-8000MARK-2SH

図番 (1/1)
 DWG. NO. C0014-M20-C

2. DISPLAY UNIT

Mounting Considerations

The display unit can be mounted on a tabletop, on the overhead, or in a panel. Install the unit where the LCD can be easily viewed and the keyboard can be easily operated. Be sure to leave sufficient space on the sides and the rear of the unit for maintenance purposes. Leave sufficient slack in cables so the unit can be dismantled from the hanger with the connectors connected.

In addition to the aforementioned points, observe the following precautions.

- Keep the display unit out of direct sunlight or at least shaded to maintain display tone and because of heat that can build up inside the cabinet.
- The ambient temperature and humidity change should be moderate and stable.
- Locate the unit away from exhaust pipes and vents.
- The mounting location should be well ventilated.
- Mount the unit where shock and vibration are minimal.
- The fuse holder in the power cable is waterproof to specification IEC529 IPX-2. Locate the power cable away from water splash.

Mounting

Mount the unit by referring to the drawing on page D-2 thru D-4.

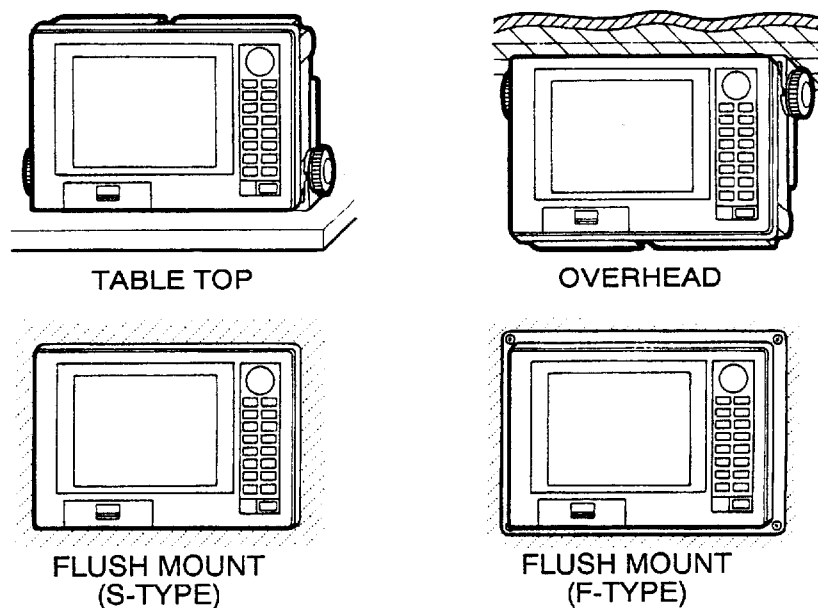

Figure 1 Display unit mounting methods

3. ANTENNA UNIT

Mounting

Install the antenna unit referring to the installation drawing on page D-1. When selecting a mounting location for the antenna unit, keep in mind the following points.

- **Select a location out of the radar beam.** The radar beam will obstruct or prevent reception of the GPS satellite signal.
- **Be sure the location offers a clean line-of-sight to satellite.** Objects within line-of-sight to a satellite, for example, a mast, block reception and cause prolonged acquiring time or interruption of position fix.
- **Mount the unit as high as possible.** Mounting the antenna as high as possible keeps it free of water spray which can intercept reception of GPS satellite signal if it freezes.

Examples of Mounting Location

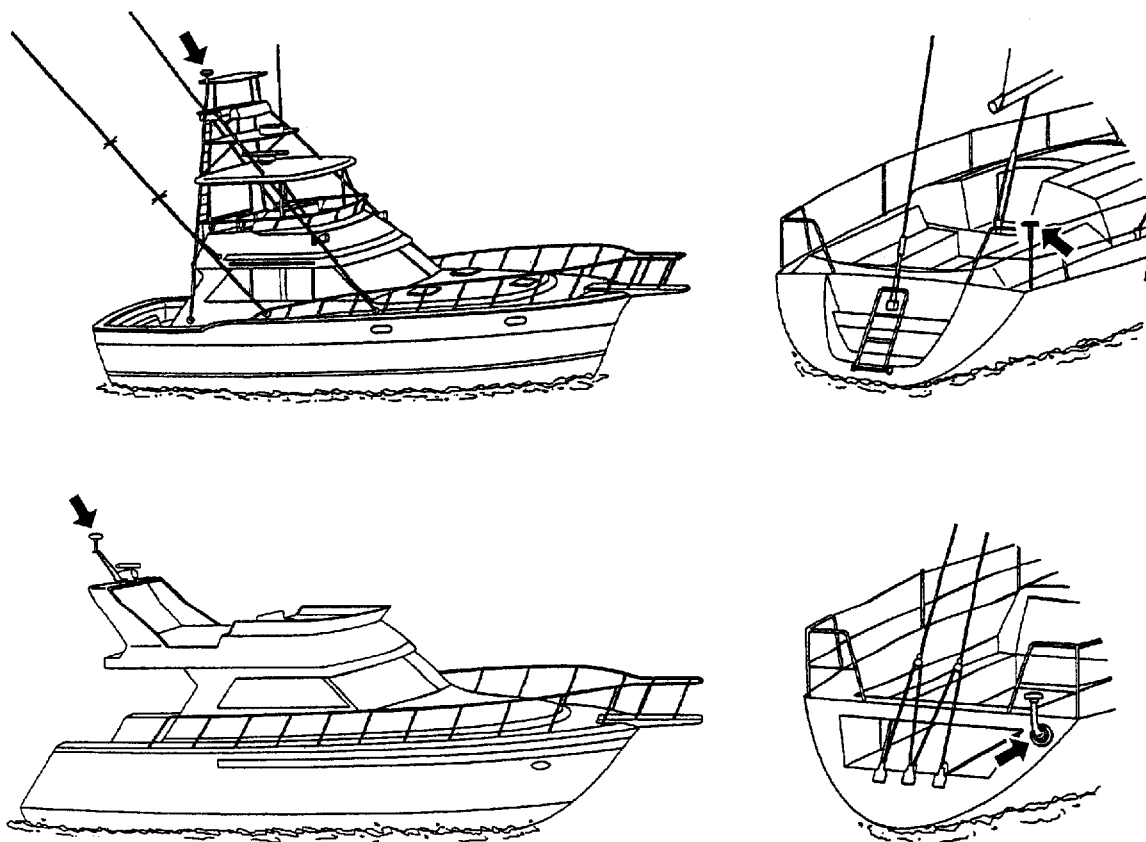

Figure 2 Antenna unit mounting locations

Fabrication of Optional Antenna Cables

The standard cable is 15 m long and comes with connectors. 30 m and 50 m long cables are optionally available.

Name	Type	Code No.
30 m Antenna Cable Set	CP20-01700	004-372-110
50 m Antenna Cable Set	CP20-01710	004-372-120

Each set contains extension cable, two connector conversion cables, coaxial connector, vulcanizing tape and vinyl tape.

◆ Fabrication of cable

- 1) Shorten the antenna cable as necessary.
- 2) Fabricate the end of the cable and attach the coaxial connector as shown on the next page.

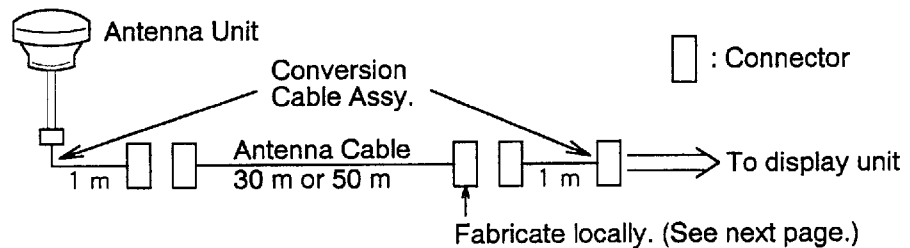

Figure 3 Installation of optional cable

◆ Waterproofing the connector

Wrap connector with vulcanizing tape and then vinyl tape. Bind the tape end with a cable tie.

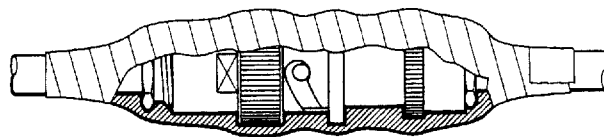
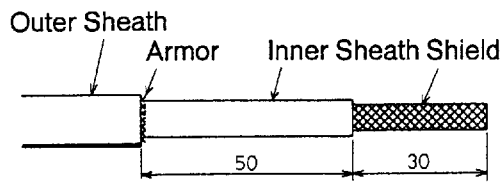

Figure 4 How to waterproof the antenna connector

How to attach the N-P-8DFB connector

(dimensions in millimeters)



Remove outer sheath and armor by the dimensions shown left. Expose inner sheath and shield by the dimensions shown left.

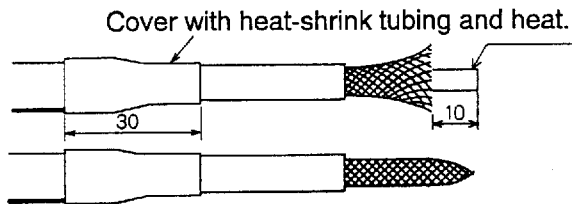

Remove insulator and core by 10 mm.

Twist shield end.

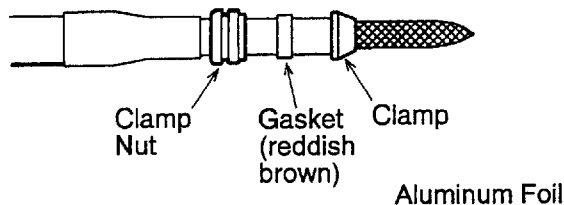

Slip clamp nut, gasket and clamp on cable as shown left.

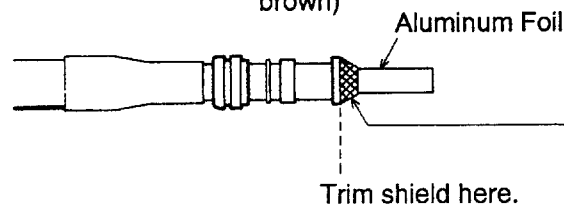

Fold back shield over clamp and trim.

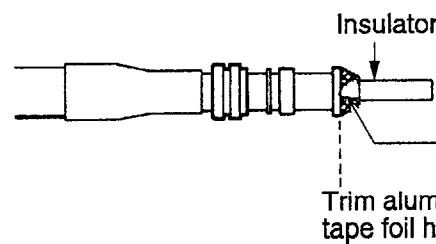
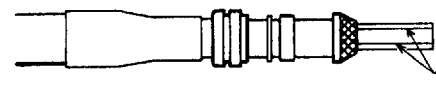

Fold back aluminum foil onto shield and trim.



Expose the insulator by 1 mm.

Expose the core by 5 mm.

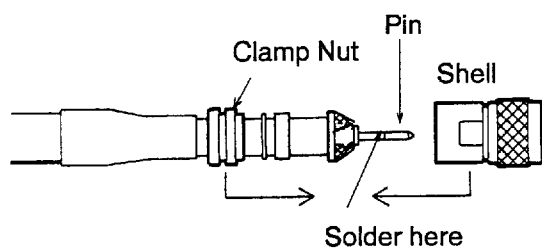

Slip the pin onto the conductor. Solder them together through the hole on the pin.

Insert the pin into the shell. Screw the clamp nut into the shell. (Tighten by turning the clamp nut. Do not tighten by turning the shell.)

Figure 5 How to attach connector N-P-8DFB

4. TRANSDUCER

Overview

The GP-1810F is available with either a transom mount, inside-hull mount or through-hull mount transducer. This section shows the installation procedure for the through-hull and transom mount transducers. For inside-hull mounting, an inner hull kit is required. Refer to the instructions contained with the kit.

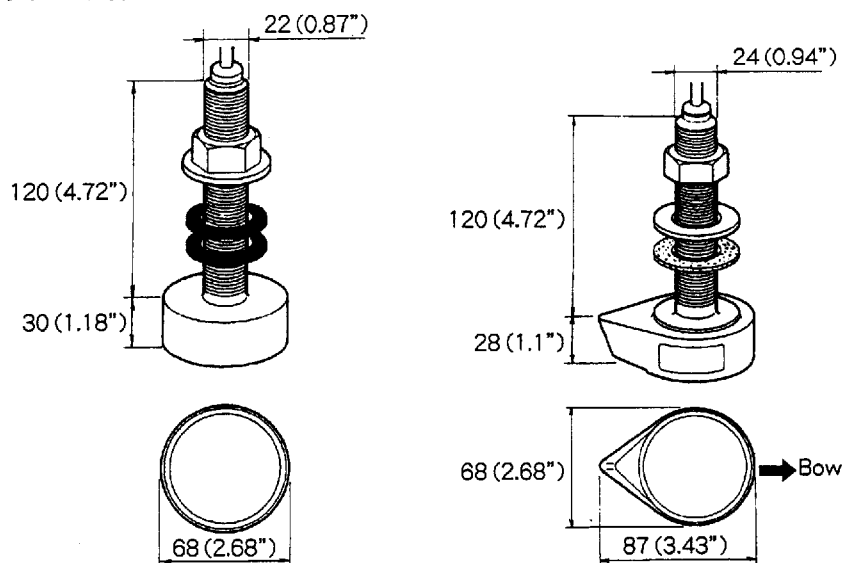

520-5PSD, Plastic with waterproof connector

520-5MSD, Bronze with waterproof connector

Figure 6 Through-hull mount transducers

Mounting Location

The performance of the video sounder is directly related to the mounting location of the transducer, especially for high-speed cruising. The installation should be planned in advance, keeping the standard transducer cable length (8 m) and the following factors in mind.

- Air bubbles and turbulence caused by movement of the boat seriously degrade the sounding capability of the transducer. The transducer should, therefore, be located in a position where water flow is the smoothest. Noise from the propellers also adversely affects performance and the transducer should not be mounted nearby. The lifting strakes are notorious for creating acoustic noise, and these must be avoided by keeping the transducer inboard of them.

- The transducer must always remain submerged, even when the boat is rolling, pitching or up on a plane at high speed.
- For displacement hulls, using inside-hull and through-hull installations, a practical choice would be somewhere between 1/3 and 1/2 of the boat's length from the stern. For planing hulls, a practical location is generally rather far astern, so that the transducer is always in the water regardless of the planing attitude.

Deep-V Planing Hulls

High Speed V-Planing Hulls

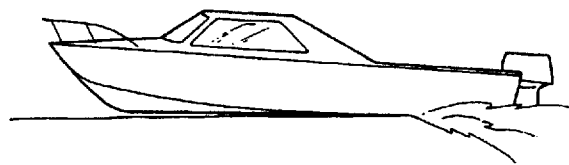
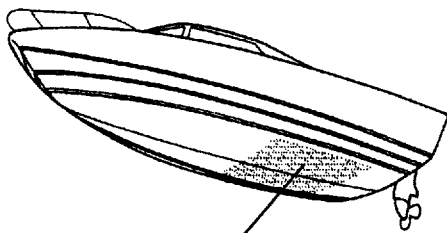

- * 1/2 to 1/3 length of the hull from stern.
- * 6" to 12" from the centerline (inside the first lifting strakes)

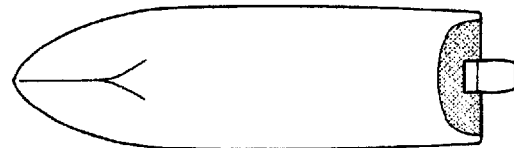
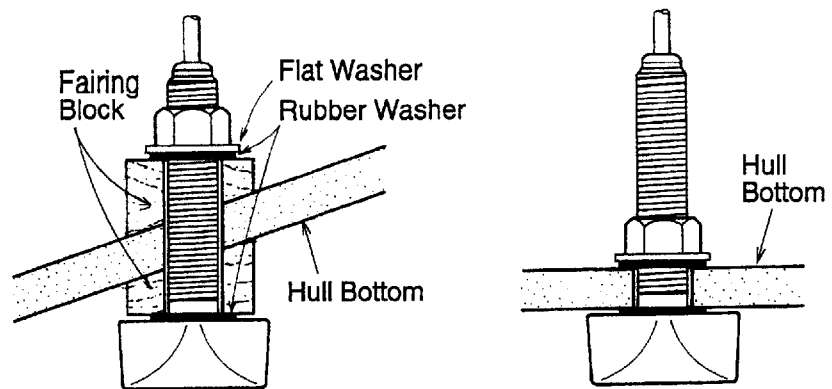

Figure 7 Transducer mounting locations

Through-Hull Mount (520-5PSD, 520-5MSD)

Overview

This type of mounting provides the best performance of all, since the transducer protrudes from the hull and the effect of air bubbles and turbulence near the hull skin is reduced. To determine the transducer location, keep in mind the general considerations noted on the previous page. Also when the boat has a keel, the transducer should be at least 30 cm (1 foot) away from it. Typical through-hull mountings are illustrated below.



Deep-V Hull

Flat Hull

Figure 8 Through-hull transducer mounting methods

Mounting Procedure

1. With the boat hauled out of the water, mark the location selected for mounting the transducer on the bottom of the hull.
2. If the hull is not level within 15 degrees in any direction, fairing blocks made out of teak should be used between the transducer and hull, both inside and outside, to keep the transducer face parallel with the water line. Construct the fairing block as shown below and make the entire surface as smooth as possible to provide an undisturbed flow of water around the transducer. The fairing block should be smaller than the transducer itself to provide a channel to divert turbulent water around the sides of the transducer rather than over its face.
3. Drill a hole just large enough to pass the threaded stuffing tube of the transducer through the hull, making sure it is drilled vertically.
4. Apply a sufficient amount of high quality caulking compound to the top surface of the transducer, around the threads of the stuffing tube and inside the mounting hole (and fairing blocks if used) to ensure watertight mounting.
5. Mount the transducer and fairing blocks and tighten the locking nuts. Be sure that the transducer is properly oriented and its working face is parallel to the waterline.

NOTE: *Do not over-stress the stuffing tube and locking nuts through excessive tightening, since the fairing block will swell when the boat is placed in the water. It is suggested that the nut be tightened lightly at installation and retightened several days after the boat has been launched.*

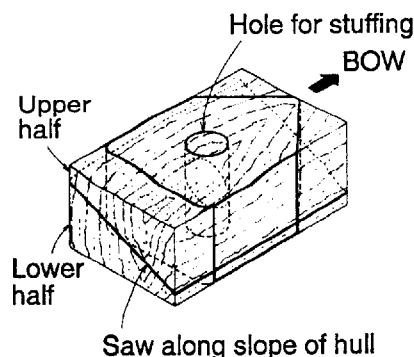

Figure 9 Construction of fairing block

Transom Mount Transducer (520-5PWD)

Overview

This type of mounting is very commonly employed, usually on relatively small I/O or outboard boats. Do not attempt this mounting on an inboard boat because turbulence is created by the propeller ahead of the transducer.

Procedure

1. Attach the transducer to the bracket.
2. To determine a suitable transducer mounting location, run the boat at several speed ranges and observe the water flow at the rear and near the transom. Suitable location is at least 50 cm away from engine and where the water flow is smooth.
3. On a relatively flat hull, the transducer is mounted flush with the hull-bottom, and there are two choices of installation as shown on the next page. Note that the direction of the transducer and fixing holes used on the brackets are different in each method. Although there is less influence from air bubbles with method (2), you must be careful not to damage the transducer when the boat is hauled out of the water/put on the trailer. On a deep "V" hull, mount the transducer using method (2). It should be mounted as near as the bottom edge of the transom, and the transducer face must be parallel with the seabed, not with the hull bottom.
4. Mark the screw locations by holding the transducer in position on the transom.
5. Drill four pilot holes.
6. Mount the transducer and secure it with four self-tapping screws. Apply a small amount of sealing compound under the head of each screw to preserve the watertight integrity of the transom.
7. Adjust the transducer position so that the transducer face is level with the sea surface the seabed.
8. If necessary, to improve water flow and minimize air bubbles staying on the transducer face, incline the transducer about 5 degrees at the rear. This may require a certain amount of experimentation for fine tuning at high cruising speeds.

9. Fill the gap between the wedge front of the transducer and transom with epoxy material to eliminate any air spaces.

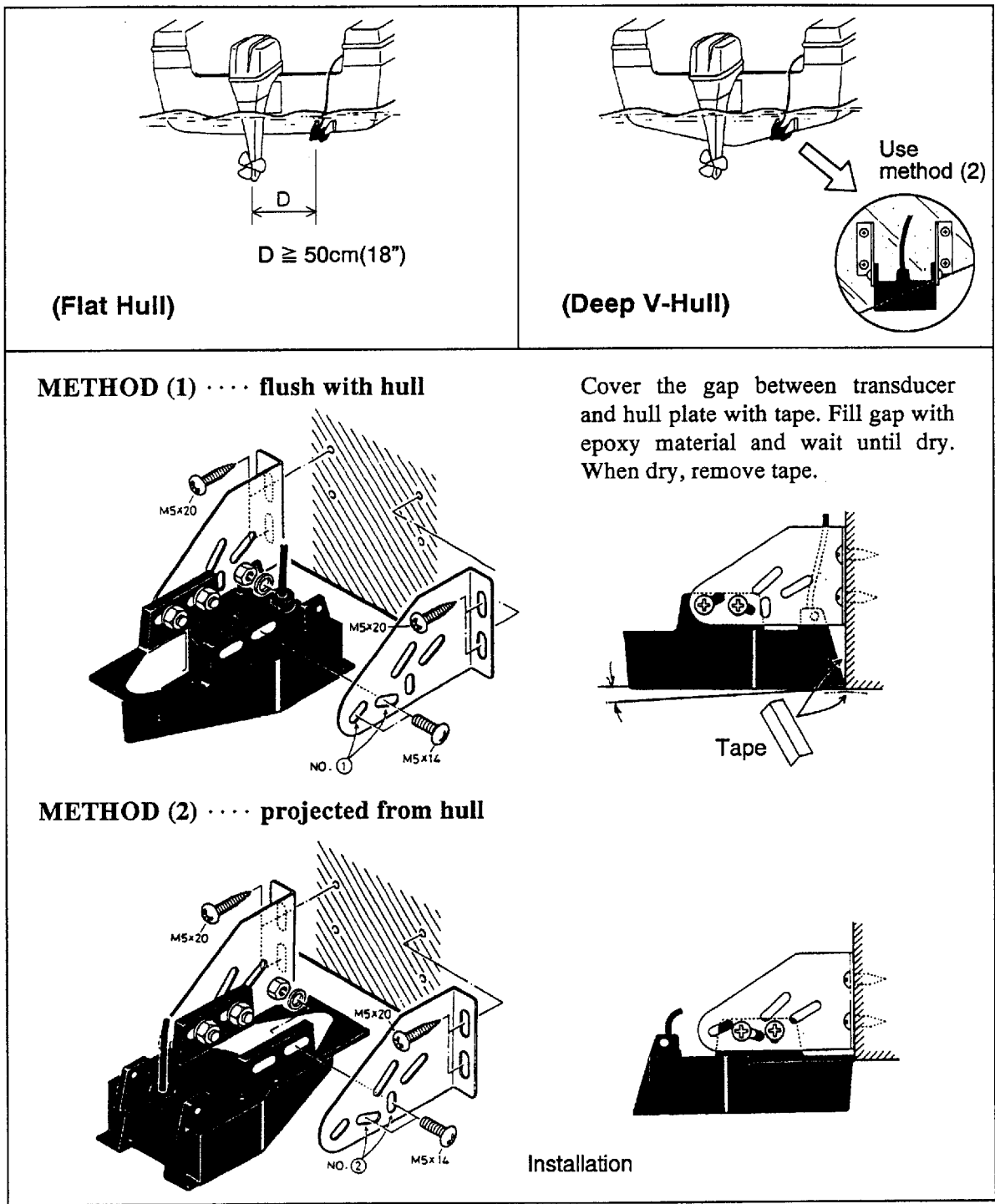

Figure 10 Transom mount transducer mounting methods

Transducer Preparation and Painting

Just before putting your boat into the water, the face of the transducer should be thoroughly wiped with a detergent liquid soap. This will lessen the time necessary for the transducer to have good contact with the water. Cutting this will lengthen the time required for complete "saturation" and will reduce the performance of the unit.

To maintain the sensitivity of the transducer, do not coat the face with heavy pigmented antifouling paints, that is, cuprous oxide types. Use only a light, thin coat of a vinyl based antifouling paint, like International Paint's TRI-LUX No.67 or No.68.

5. SPEED/TEMPERATURE SENSOR

Transom Mount Temperature Sensor (T-02MTB)

Mounting Location and Mounting Method

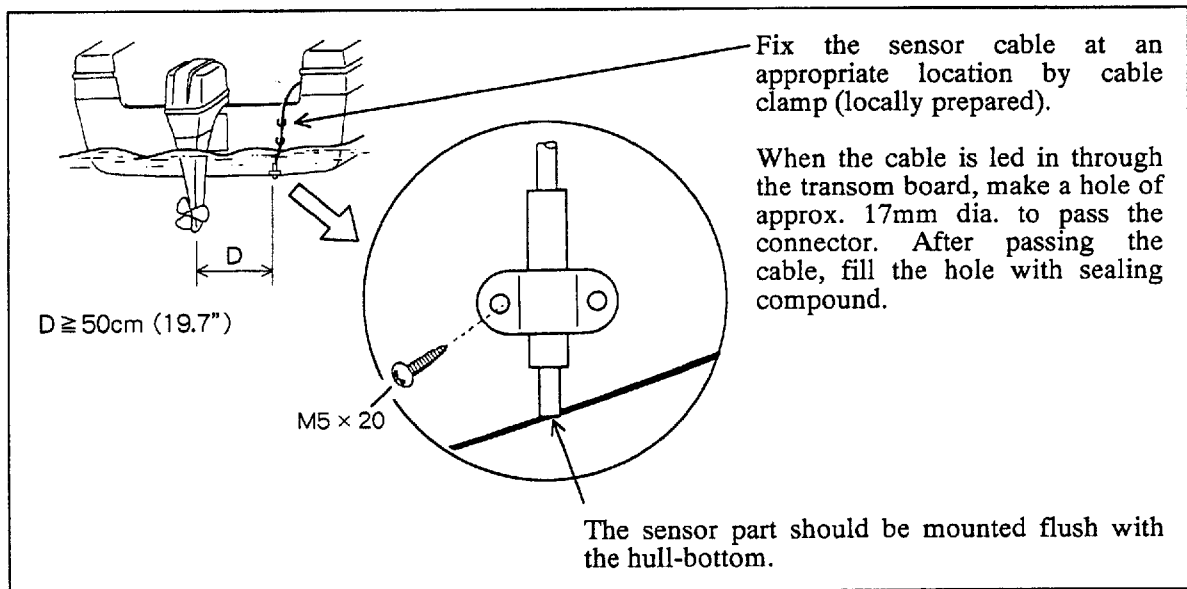

Figure 11 How to mount transom mount temperature sensor

Thru-Hull Mount Temperature Sensor (T-03MSB)

Mounting Location

- Select a mid-boat flat position. The sensor does not have to be installed perfectly perpendicular. The sensor must not be located where it might be damaged when the boat is dry docked or put on a trailer.
- Select a place apart from equipment generating heat.
- Select a place in forward direction viewing from the drain hole for cooling water.
- Select a place free from vibration.

Mounting Procedure

- 1) Dry-dock the boat.
- 2) Make a hole of approx. 25mm on the hull bottom.
- 3) Run the sensor cable through the hole.
- 4) Apply high grade sealant to the flange of the sensor.
- 5) Pass the cable through the rubber gasket, washer and the locknut as shown below.
- 6) Tighten the locknut. Do not tighten the nut excessively.
- 7) After launching, check for water leakage around the sensor.

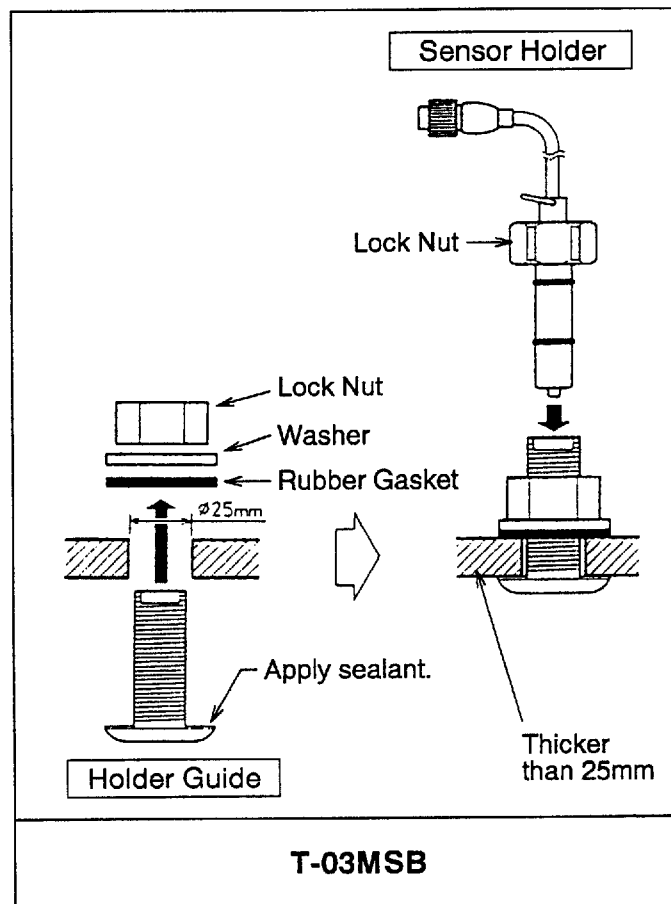

Figure 12 How to mount thru-hull mount temperature sensor

Through-Hull Mount Speed/Temperature Sensor (ST-01MSB)

Refer to the installation manual attached to the sensor.

6. WIRING

The figure below shows the connection of cables at the rear of the display unit.

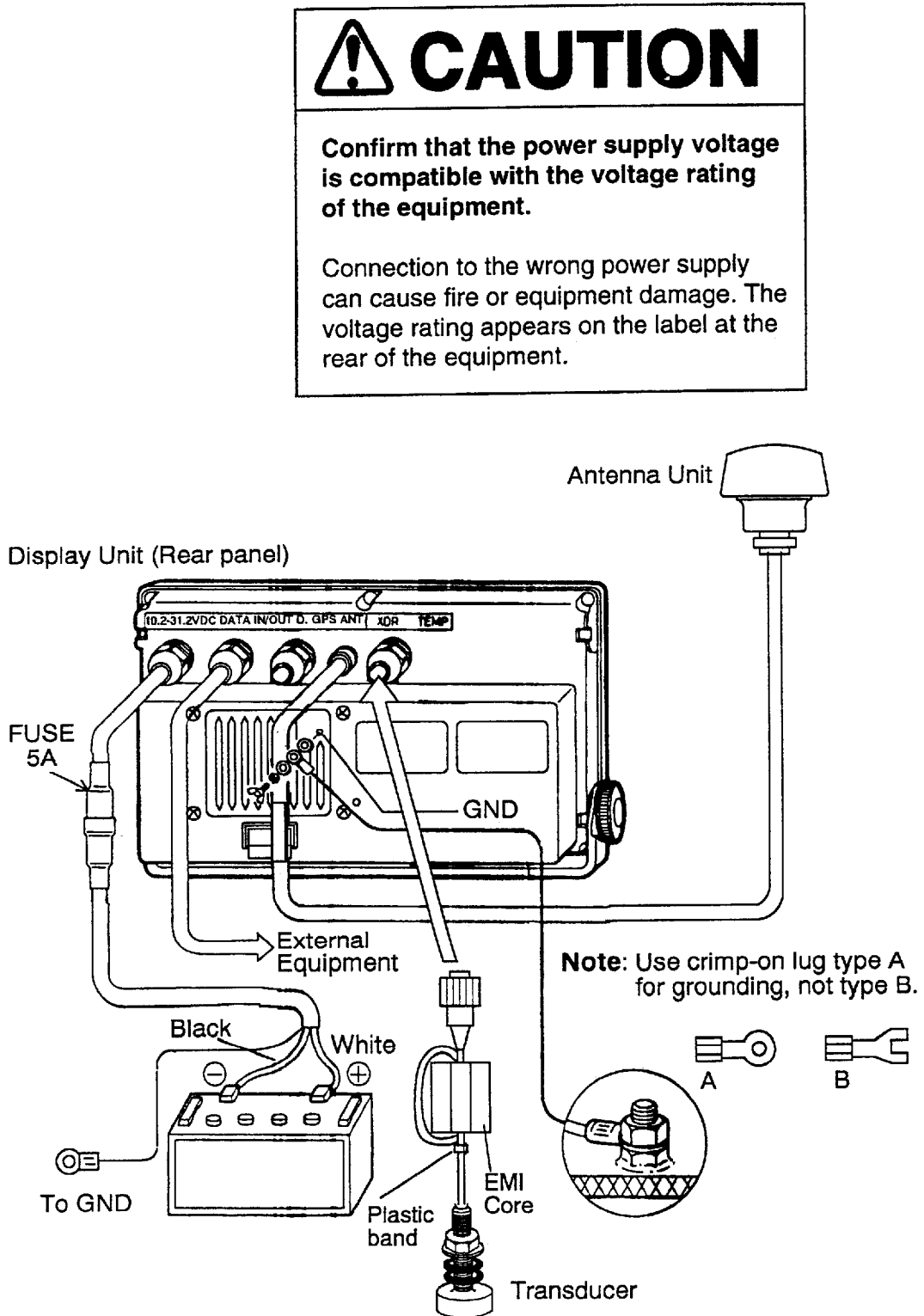

Figure 13 Connection at rear of display unit

Antenna Cable

Connect the antenna cable to the **GPS ANT** jack at the rear of the display unit.

Power Cable and Ground

The display unit operates on 10.2 to 31.2 VDC (measured at **POWER** jack on display unit). Connect the plug on the power cable to the **POWER** jack at the rear of the display unit. Connect the other end to the power supply; white wire to the plus (+) terminal, black wire to the minus (-) terminal, and shield wire to bolt fastened to ship's superstructure.

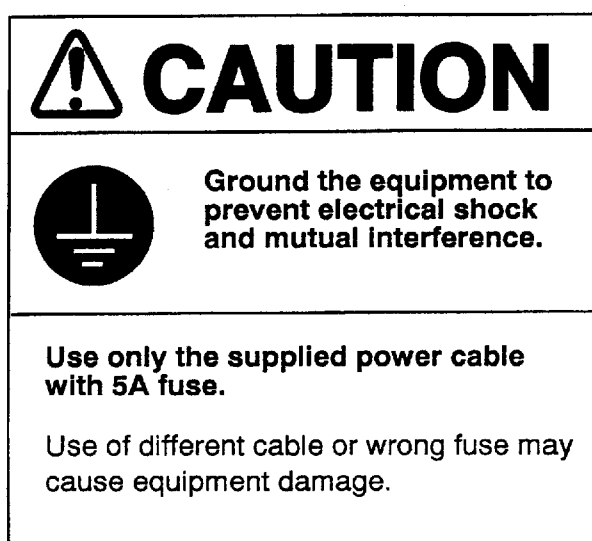

Transducer Cable

In order to minimize the possibility of picking up electrical interference, avoid where possible routing the transducer cable near other on-board electrical equipment. Also avoid running the cable in parallel with power cables.

Note: The XDR jack is for a 10-pin waterproof connector which is fitted with the 520-PSD, 520-MSD and 520-PWD type transducers. For a transducer with an 8-pin connector, connect an optional 8P-10P conversion cable (type 02S4089-0, code no. 000-133-622) between the transducer cable and the XDR jack.

Attaching EMI Core

A EMI core is supplied with the installation materials. It functions to suppress radio interference. Attach it as close as possible to the connector end of the transducer cable and fix it by plastic band as shown figure 13.

External Equipment

The DATA I/O port connects external equipment such as autopilot, radar, or navigation equipment. An interconnection cable is optionally available. See the equipment list on page 2.

DGPS Receiver

The DGPS jack connects DGPS receiver, which picks up a beacon signal (RS-232C or RS-422 level) for correction of GPS position fix.

Connection for RS-232C level Beacon Receiver

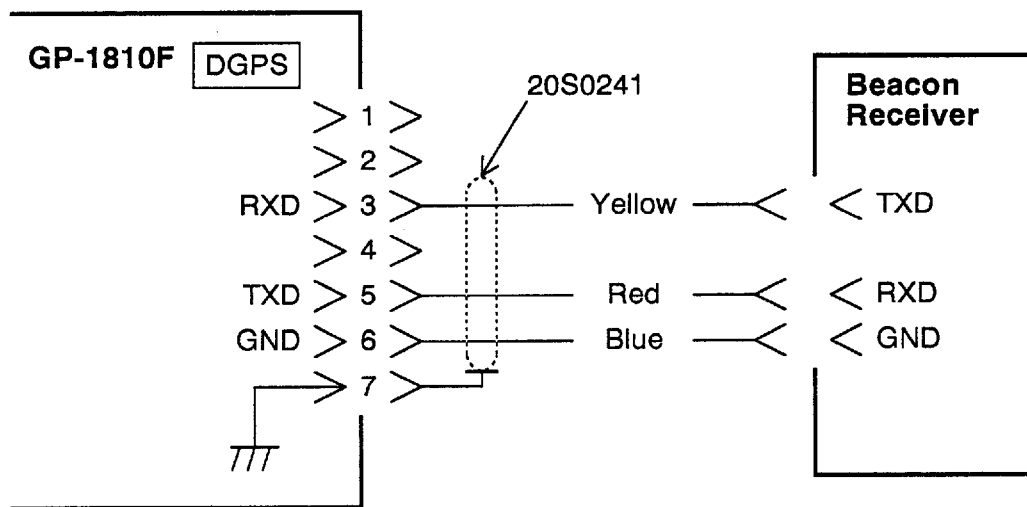

Figure 14 Connection of RS-232C level beacon receiver

Connection for RS-422 level Beacon Receiver

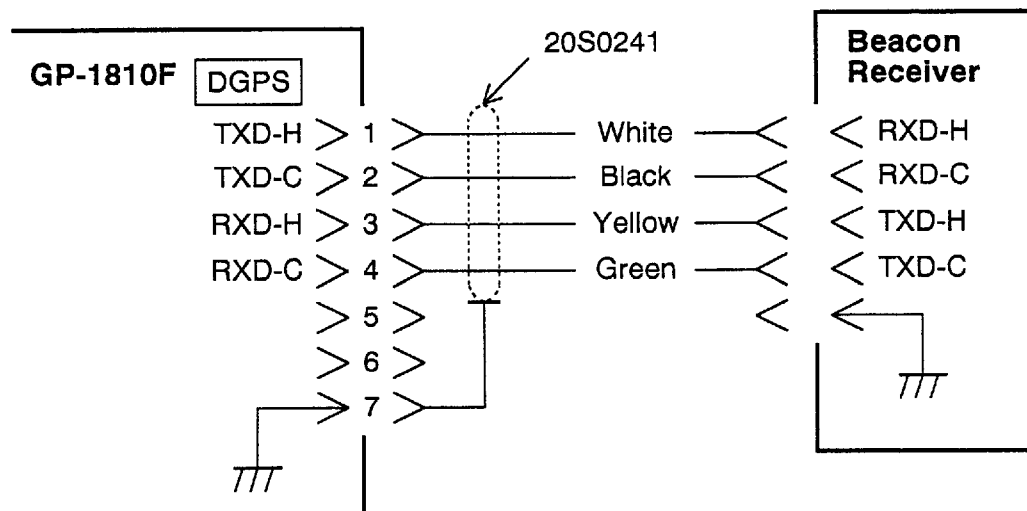

Figure 15 Connection of RS-422 level beacon receiver

7. INITIAL SETTINGS

After installing the unit, turn the unit on and set the SYSTEM SETUP menu as follows.

Procedure

- 1) Press the **MENU** key. The MAIN menu appears.
- 2) Press **9** to display SYSTEM SETUP menu.
- 3) Set the items using the arrow keys and numeral keys according to the user's requirements. The figure below circumscribes factory settings. Items marked by arrows on this and the next page must be set after installation.

SYSTEM SETUP 1/3		▲▼ : Next, previous page		
Memory Apportion	Trk=	2000Pt/4000Pt		
Unit of Distance	<input type="text" value="nm"/>	km	sm	
Unit of Depth	<input type="text" value="m"/>	<input type="text" value="ft"/>	Fa	ヒロ PB
Unit of Temp	<input type="text" value="°C"/>	°F		
Navaid	<input type="text" value="Int. GPS"/>	Ext. GPS	LC	DC All
Scale/Range	Scale	<input type="text" value="Range"/>		
Rec Resolution	2			
Posn Display	<input type="text" value="Lat/Long"/>	LOP		
LOP Display	LA	LC	<input type="text" value="No"/>	
LA Chain	00-01	△ +000.0 μ s	△ +000.0 μ s	
LC Chain	00:11-26	△ +000.0 μ s	△ +000.0 μ s	
Smoothing Factor	00 (0-15)			
Spd Average Time	01 minute			
Bearing Ref.	True Brg	<input type="text" value="Mag Brg"/>		
Mag. Variation	<input type="text" value="Auto (07°W)"/>	Man (00°E)		
Output Data Fmt	NMEA 180	<input type="text" value="NMEA 183V1.5"/>	NMEA 183V2.0	
External Device	<input type="text" value="Autopilot"/>	AD + RADAR	Navaid	
▲▼◀▶ : Select		ENT: End	MENU: Escape	

Figure 16 System Setup menu 1/3 page

SYSTEM SETUP 2/3		▲▼ : Next, previous page
→ Temperature Offset	+00.0 °C	
→ Water Depth Offset	+00.0ft (- 5.0~+50.0)	
TX Power	Low <input type="checkbox"/> Normal <input checked="" type="checkbox"/>	
EXP Range	× 2 <input type="checkbox"/> × 3 <input checked="" type="checkbox"/> × 4 <input type="checkbox"/> × 5 <input type="checkbox"/>	
EXP Marker	On <input type="checkbox"/> Off <input checked="" type="checkbox"/>	
TVG	3 (Low 0 - 9 High)	
Echo Level Offset	+00 (- 20~+20)	
Bottom Lock Range	<input checked="" type="checkbox"/> Narrow <input type="checkbox"/> Wide	
Fish Alarm Level	Dark <input type="checkbox"/> Med <input checked="" type="checkbox"/> Light <input type="checkbox"/>	
Seabed Level	080 (20 - 150)	
→ Speed Source	Speed Sensor <input type="checkbox"/> GPS <input checked="" type="checkbox"/>	
→ Speed Correction	+00% (- 50~+50)	
▲▼◀▶ : Select ENT: End MENU: Escape		

SYSTEM SETUP 3/3		▲▼ : Next, previous page
→ Time Difference	+00:00	
GPS Posn Smooth	00 (00-99)	
GPS Speed Smooth	05 (00-99)	
→ Antenna Height	+005m	
DOP Threshold	20 (2-99)	
Fix Mode	2D <input type="checkbox"/> 2/3D <input checked="" type="checkbox"/>	
→ Geodetic Datum	Tokyo <input type="checkbox"/> WGS-84 <input checked="" type="checkbox"/> WGS-72 <input type="checkbox"/> Other (___)	
Position Offset	00.000'N 00.000'E	
Disabled Satellite	<input checked="" type="checkbox"/> Rstr <input type="checkbox"/> Disable (___)	
D.GPS Mode	On <input type="checkbox"/> Off <input checked="" type="checkbox"/>	
RTCM Version	1.0 <input type="checkbox"/> 2.0 <input checked="" type="checkbox"/>	
Byte Format	<input checked="" type="checkbox"/> 8-6 <input type="checkbox"/> 8-8	
→ First Bit	MSB <input type="checkbox"/> LSB <input checked="" type="checkbox"/>	
Parity Bit	EVEN <input type="checkbox"/> ODD <input type="checkbox"/> NONE <input checked="" type="checkbox"/>	
Stop Bit	<input checked="" type="checkbox"/> 1 <input type="checkbox"/> 2	
Bit Rate	7 <input type="checkbox"/> 8 <input checked="" type="checkbox"/>	
Baud Rate	9600(300 ◀▶ 9600)	
→ Clear Memory	<input checked="" type="checkbox"/> No <input type="checkbox"/> PLT <input type="checkbox"/> GPS <input type="checkbox"/> All	
Position	38° 00.000'N 123° 00.000' W	
→ D.GPS Level	RS-422 <input type="checkbox"/> RS-232C <input checked="" type="checkbox"/>	
▲▼◀▶ : Select ENT: End MENU: Escape		

Figure 17 System Setup menu 2/3 and 3/3 pages

Entering Antenna Height

- 1) Select the ANT HEIGHT item using the arrow keys.
- 2) Enter the height (3 digits) of the GPS antenna above sea level using the numeral keys.
- 3) Press the **ENT** key.

Entering Time Difference/Geodetic Datum

- 1) To use local time instead of UTC time enter time difference between local time and UTC time; + for eastern longitude, – for western longitude.
- 2) Enter geodetic datum referring to nautical chart for your operating area. See separate operator's manual for further details.

Setting for External Navigation Equipment

The following settings are required when external navigation equipment; autopilot, remote display, etc., is connected to the DATA IN/OUT and DGPS jacks.

- 1) "Navaid" selection
Normally INT GPS position is selected. If the internal GPS receiver becomes defective, select the Ext GPS, LC (Loran C) or DC (Decca navigator) position as applicable. The selected navigation equipment is indicated at the upper right corner on the display.
- 2) "Output Data Format" selection
Set a communication format according to the connected navigation equipment.

NMEA 0180 simple data format

Cross track error is output.

NMEA 0183 version 1.5 or 2.0 data format

Output Data

	Sentence
For Autopilot	AAM, APA (ver. 1.5), GLL, VTG, XTE, APB (ver. 2.0), BOD, BWC
For AP + RADAR	AAM, APA (ver. 1.5), GLL, VTG, XTE, APB (ver. 2.0), BOD, BWC, BWR, MTW, RMC, VTG, ZDA, DBT (ver 1.5), DPT (ver 2.0), RMB, GGA, GTD
For Navaid	GLL, MTW, RMC, VTG, BWR, ZDA, RMB, DBT (ver. 1.5), DPT (ver. 2.0) GGA, GTD, XTE

Input Data

	Sentence
For autopilot	AGFPA, GGA, GLL, BWC, RMA, VTG, ZDA, MTW, WPL, TLL
For AP + RADAR	BWR, GGA, GLL, MTW, RMA, RMB, RMC, WPL, TLL, VTG, ZDA
For Navaid	GGA, GLL, MTW, RMA, RMB, RMC, VTG, BWR, WPL, TLL, ZDA

3) "External Device" selection

Select a connected navigation equipment; autopilot, remote display or external navigation equipment.

Setting for DGPS Beacon Receiver

Set the DGPS MODE to the ON position using arrow keys and set the following items, by referring to the specifications of the DGPS beacon receiver.

- | | |
|-----------------|---------------|
| 1) DGPS MODE | 6) Stop Bit |
| 2) RTCM Version | 7) Bit Rate |
| 3) Byte Format | 8) Baud Rate |
| 4) First Bit | 9) DGPS Level |
| 5) Parity Bit | |

Temperature Offset

Enter an offset value if the water temperature reading is deviated from the true value.

Water Depth Offset

Depth reading is based on the transducer position fitted on the boat's hull. If a depth reading relative to water surface is required, enter boat's draft depth between water surface and the hull.

Speed Source

Normal setting is "GPS". If you want to display ship's speed (water tracking) measured by an optional speed sensor instead of ground speed measured by the GPS receiver, select "Speed Sensor."

Speed Correction

Enter a correction value if speed reading is deviated from the true value. This correction is effective only for an optional speed sensor.

A) Mast mounting

Use mast mounting kit CP20-01111.

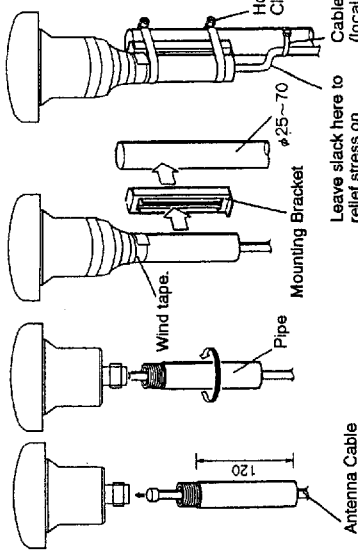

NOTES

- 1) Fasten pipe to antenna first then fix them to mast.
- 2) When fixing antenna to pipe, turn pipe; turning the antenna may twist the cable and place stress on connector.

Leave slack here to relieve stress on connector.

B) Antenna base mounting

Use optional antenna base No.13-QA300 or No.13-QA310.

Inclination	-5° to 33°	32° to 65°	65° to 98°
Right angle antenna base No.13-QA300 (code No. 000-803-239)			
L-type antenna base No.13-QA310 (code No. 000-803-240)			

C) Handrail mounting

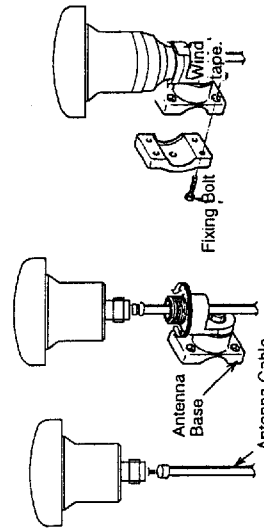

Use handrail mounting base No.13-RCS160 (Code No. 000-861-114, option). The diameter of the handrail may be from $\phi 19\text{mm}$ to $\phi 32\text{mm}$.

NOTES

- 1) Fasten antenna base to antenna first then fix them to handrail.
- 2) When fixing antenna to antenna base, turn antenna base; not the antenna. Turning the antenna may twist the cable and place stress on connector.

Mounting location

The figure below shows the recommended separation distances from other antennas to avoid mutual interference.

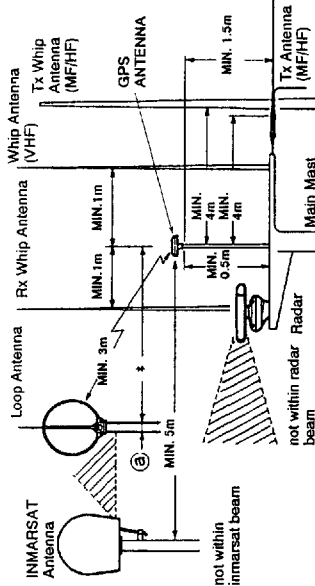

* Distance depends on mast diameter of ①
 ① mast diameter 10cm : minimum 1.5m
 ② mast diameter 30cm : minimum 3m

Mounting dimensions of antenna base (option)

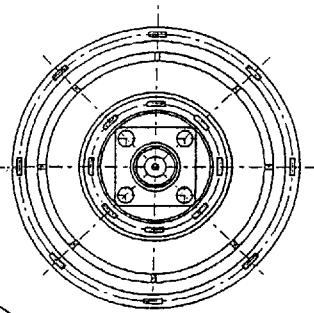
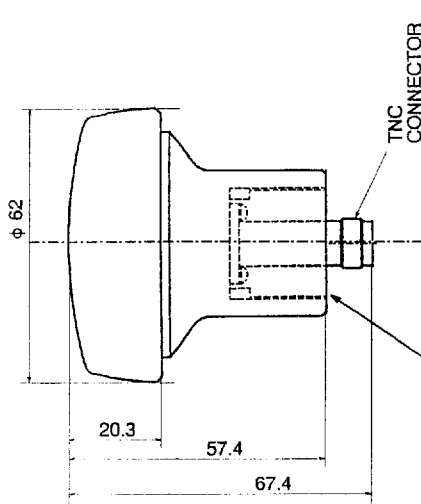
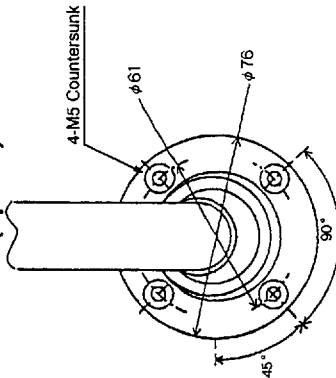

Thread Type	Threads per 25.4 mm (1 inch)	Pitch	Thread Length	Pitch Diameter
1 X 14UNS1B	14	1.8143 mm	15.17 mm	24.17 mm

DRAWN Oct. 95 Checked Oct. 95 Approved Oct. 11 95 Scale 1:1	Y. T. Yamada T. TAHARA K. OHTA	TYPE 名称 GP-50MK3 PS-8000M2 GP-1600/F GP-8000M2 GP-3100M2 GP-80	BLOCK NO.	NAME ANTENNA UNIT
APPLICABLE TO: (MODEL)		GPAD16 空中線部 外寸図		
Dwg. No. E4374-604-D		OUTLINE DRAWING		

1 2 3 4

5-φ6 装備用穴
FIXING HOLES

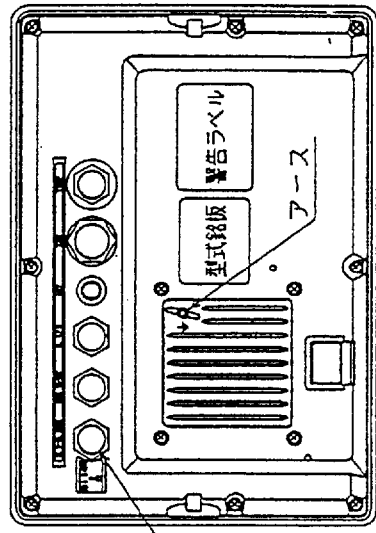

矢視 A
VIEW A

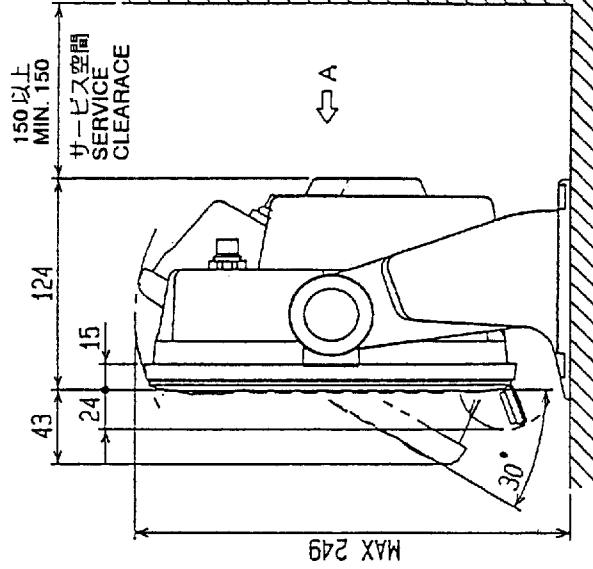
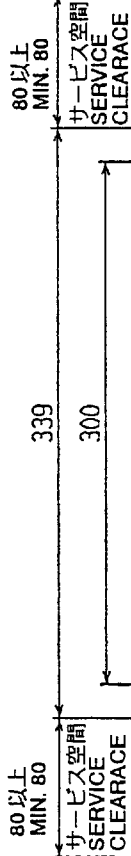
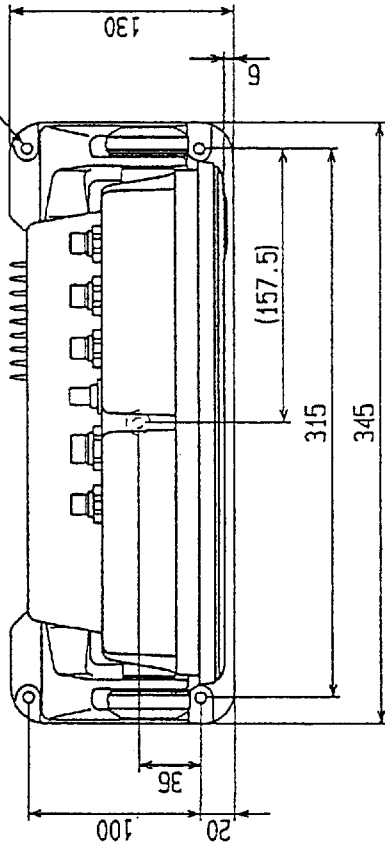

DRAWN Feb. 7, '96 M. YOSHII	TYPE GP-1810/F
CHECKED Feb. 7 '96 TAKAHASHI	名称 GPSプロッタ/GPSプロッタ魚探
APPROVED AKIYAMA Taro	外寸図
SCALE 3 kg	GPS PLOTTER/SOUNDER
APPLICABLE TO: GP-1810/F (MODEL)	BLOCK NO.
DMG NO. C4377-G02-A	14-054-1000-G1
OUTLINE DRAWING	

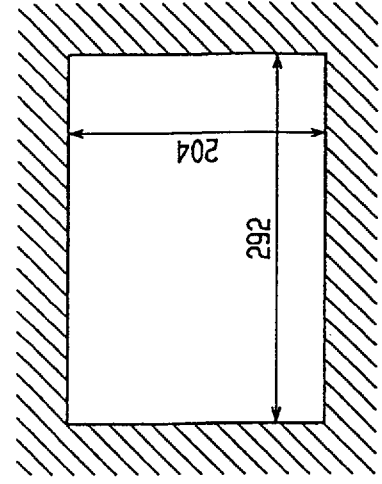
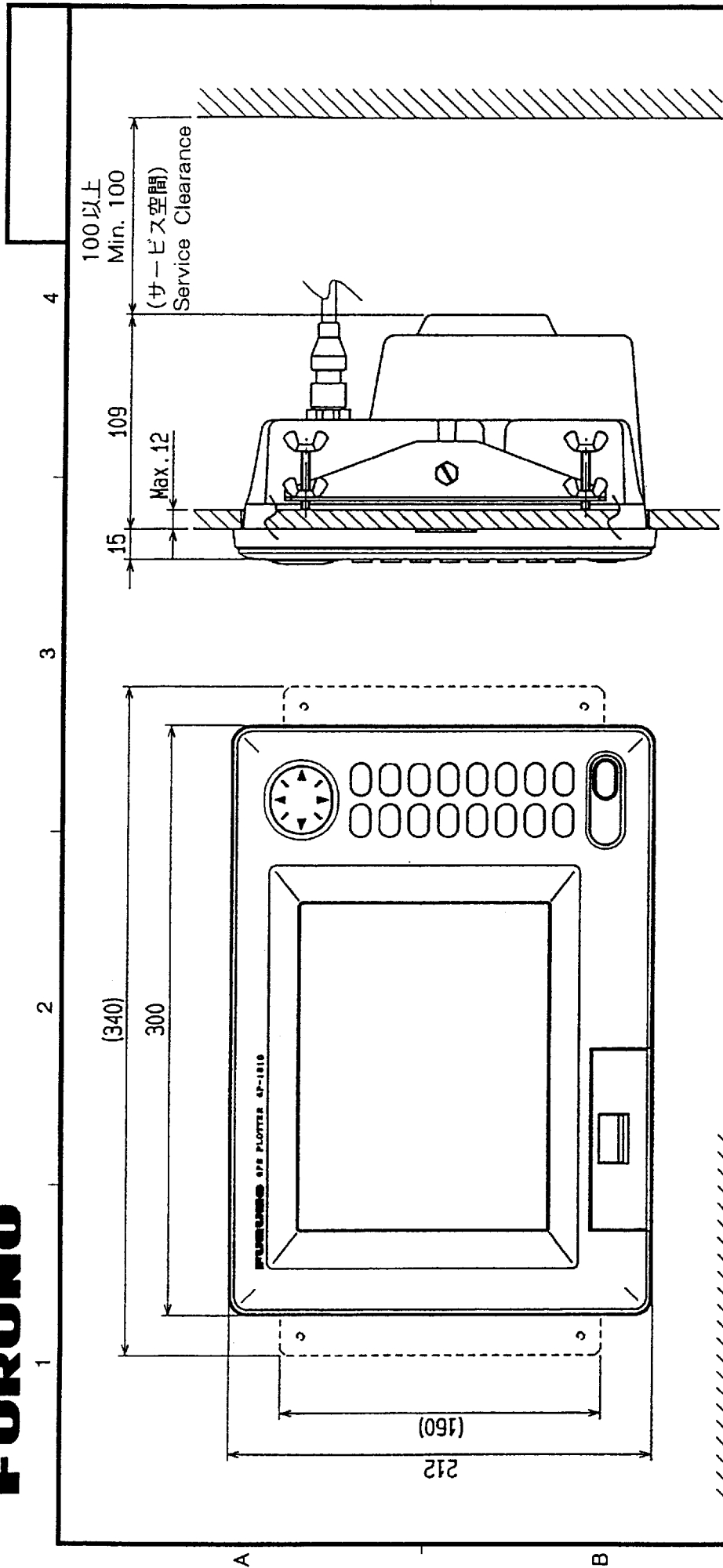

取付寸法図 (参考図)
 (尺度 1/6)
 Cutting Dimension (Reference)
 Scale 1/6

表 1 TABLE 1

範囲 DIMENSIONS	公差 TOL
L ≤ 50	± 0.1mm
50 < L ≤ 100	± 0.2mm
100 < L ≤ 500	± 0.3mm

DRAWN JUN. 16 '97
 CHECKED T. YAMASAKI
 JUN. 16 '97 K. Kusunoki
 APPROVED June 16 '97
 H. Yamaguchi
 SCALE 1/3 MASS 3 kg
 DWG NO. C4378-G01-B

TYPE	GP-1810/F
名称	GPSプロッタ (フラッシュマウントS)
外寸図	
NAME	GPS PLOTTER (FLUSH MOUNT S)
BLOCK NO.	
APPLICABLE TO: (MODEL)	GP-1810F GP-1810
14-054-1210-G0	
OUTLINE DRAWING	

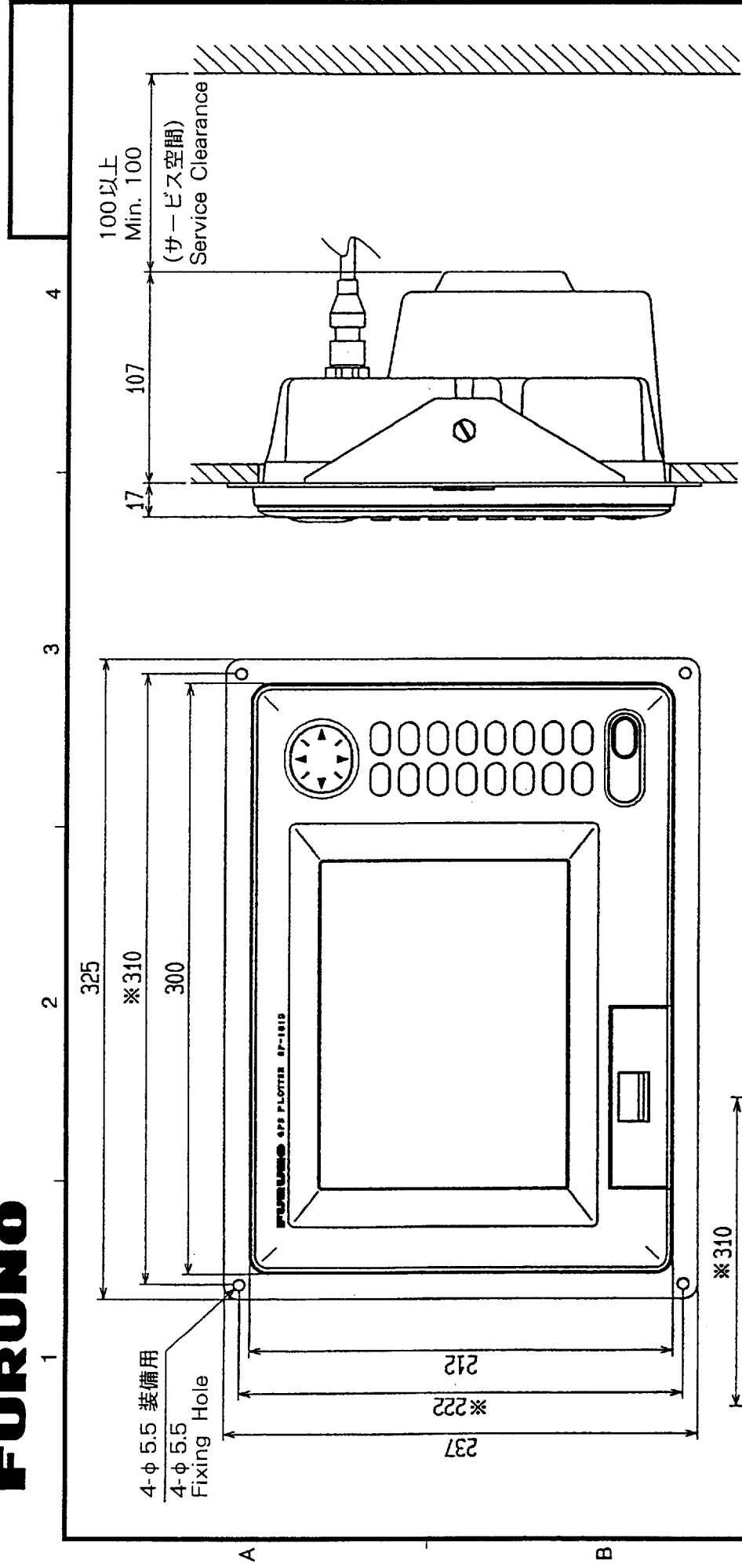

注 1) ※印寸法は取付穴位置寸法とする。
 注 2) 取付けネジはタッピングネジ呼び径5×20を使用。
 Note 1) ※: MOUNTING DIMENSIONS
 Note 2) USE TAPPING SCREWS φ 5x20 FOR FIXING THE UNIT

表 1 TABLE 1
 取付寸法 (寸法) 公差 (TOL)

L	±0.10
W	±0.10
H	±0.10

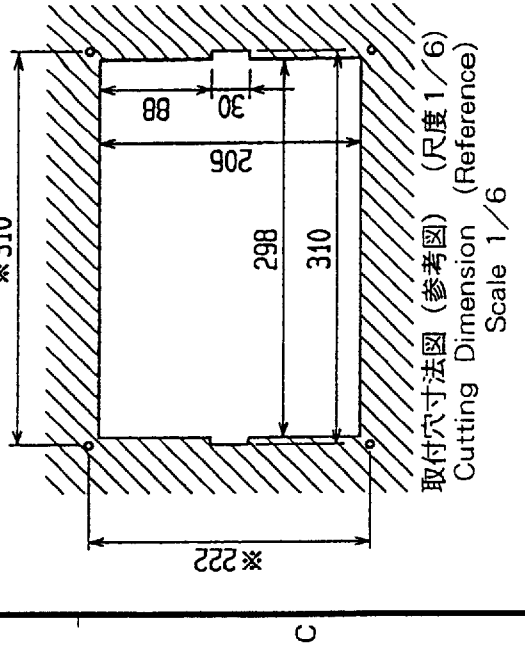

TYPE	GP-1810/F
名称	GPSプロッタ (フラッシュユニットF)
外寸図	
NAME	GPS PLOTTER (FLUSH MOUNT F)
BLOCK NO.	
APPLICABLE TO:	GP-1810F
(MODEL)	GP-1810
DWG NO.	C4378-G02-B
SCALE	1/3
MASS	3 KG
CHECKED	T. YAMASAKI
DRAWN	JUN. 16 '97
APPROVED	JUN. 16 '97 K. KUSUNOKI
APPLICABLE TO:	4. Yamaguchi ph. c.
OUTLINE DRAWING	

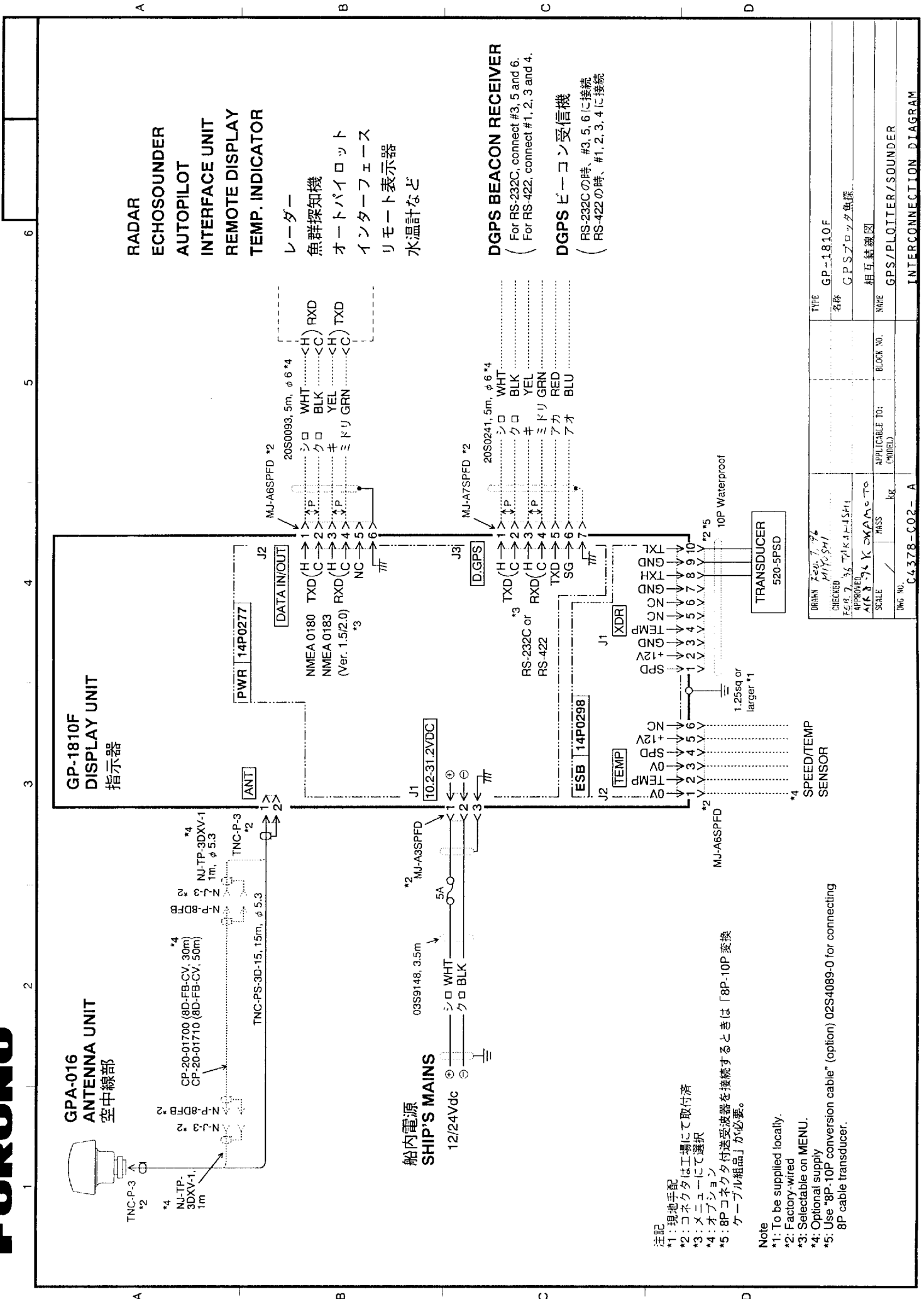

注記
 *1: 現地手配
 *2: コネクタは工場にて取付済
 *3: メニューにて選択
 *4: オプション
 *5: 8P コネクタ付送受波器を接続するときは「8P-10P 変換ケーブル組品」が必要。

Note
 *1: To be supplied locally.
 *2: Factory-wired
 *3: Selectable on MENU.
 *4: Optional supply
 *5: Use "8P-10P conversion cable" (option) 02S4089-0 for connecting 8P cable transducer.

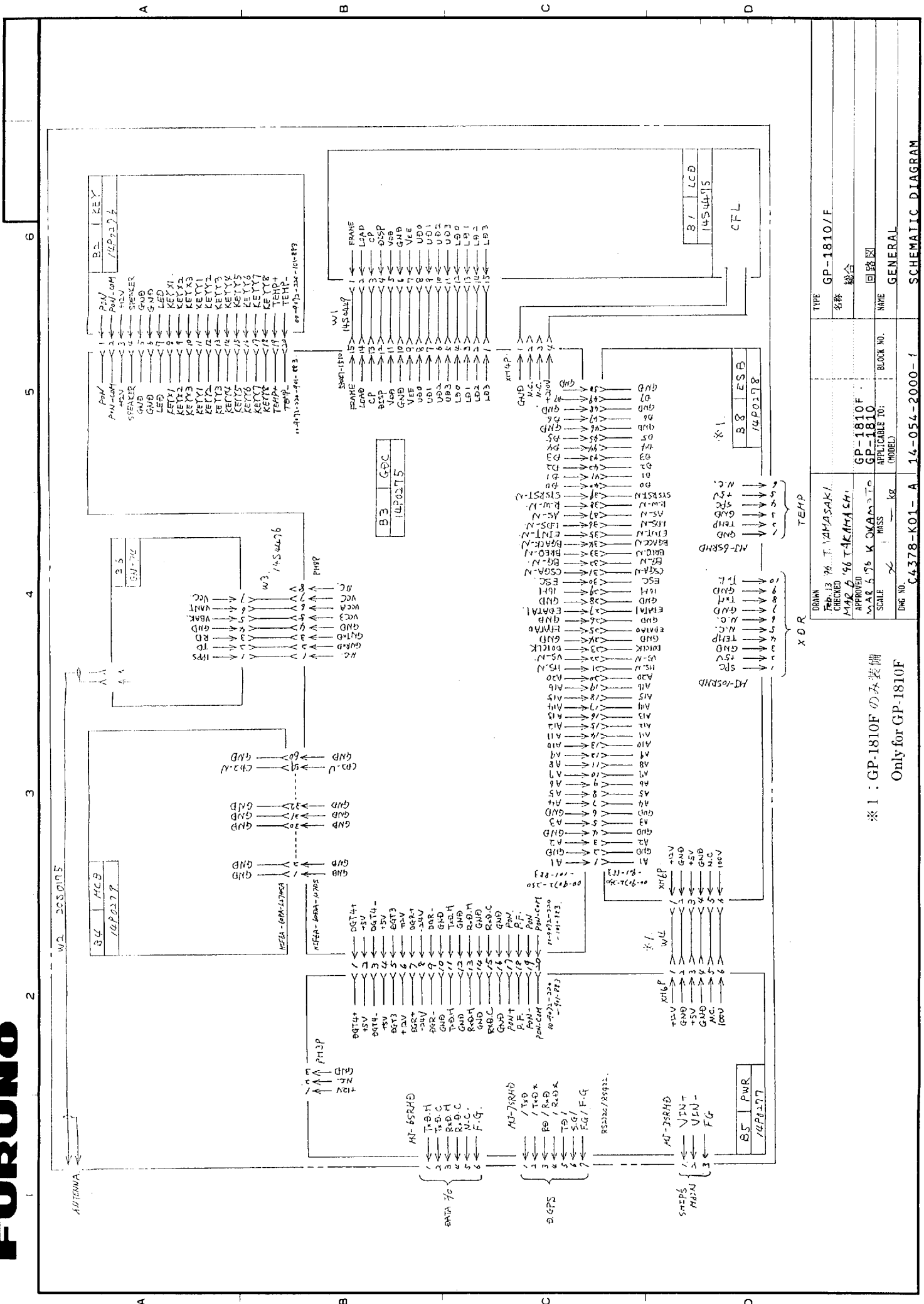

TYPE	GP-1810/F
名称	総合
回路図	回路図
GENERAL	GENERAL

DRWN	Tab. 13 76 T. YAMASAKI
CHECKED	M42 6 '96 TAKAHASHI
APPROVED	MAR 5 '96 K. OKAMOTO
SCALE	1/1000
APPLICABLE TO:	GP-1810F GP-1810 (MODEL)
BLOCK NO.	
DWG NO.	C4378-K01-A

※ 1 : GP-1810F のみ装備
Only for GP-1810F

TYPE	GP-1810/F
名称	総合
回路図	回路図
GENERAL	GENERAL

A

B

C

D

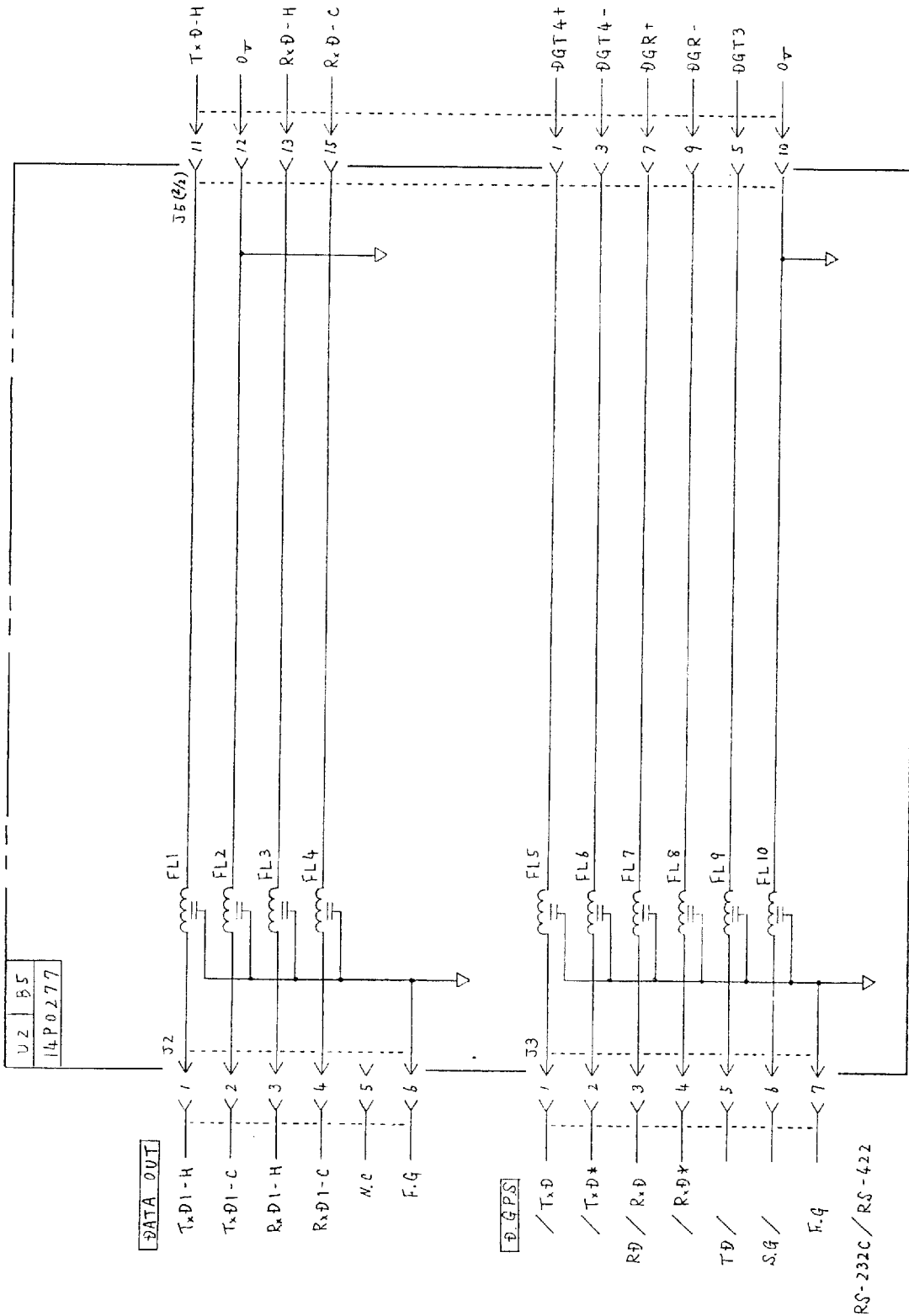

DRAWN Feb. 13 '96 T. YAMASAKI CHECKED MAR 6 '96 TAKAHASHI APPROVED MAR 6 '96 KCKAMATO SCALE MASS - kg DWG NO. C4378-K03- A	GP-1810F GP-1810 APPLICABLE TO: (MODEL) BLOCK NO. 2B 5 2B 5	TYPE 14P0277 名称 電源部 2 回路図 NAME POWER BOARD (2) SCHEMATIC DIAGRAM
--	---	---